

MUTATIONS IN SARCOMERE PROTEIN GENES AS A CAUSE OF DILATED CARDIOMYOPATHY

MITSUHIRO KAMISAGO, M.D., SAPNA D. SHARMA, M.D., STEVEN R. DEPALMA, PH.D., SCOTT SOLOMON, M.D., PANKAJ SHARMA, M.D., PH.D., BARBARA McDONOUGH, R.N., LESLIE SMOOT, M.D., MARY P. MULLEN, M.D., PH.D., PAUL K. WOOLF, M.D., E. DOUGLAS WIGLE, M.D., J.G. SEIDMAN, PH.D., AND CHRISTINE E. SEIDMAN, M.D.

ABSTRACT

Background The molecular basis of idiopathic dilated cardiomyopathy, a primary myocardial disorder that results in reduced contractile function, is largely unknown. Some cases of familial dilated cardiomyopathy are caused by mutations in cardiac cytoskeletal proteins; this finding implicates defects in contractile-force transmission as one mechanism underlying this disorder. To elucidate this important cause of heart failure, we investigated other genetic causes of dilated cardiomyopathy.

Methods Clinical evaluations were performed in 21 kindreds with familial dilated cardiomyopathy. A genome-wide linkage study prompted a search of the genes encoding β -myosin heavy chain, troponin T, troponin I, and α -tropomyosin for disease-causing mutations.

Results A genetic locus for mutations associated with dilated cardiomyopathy was identified at chromosome 14q11.2–13 (maximal lod score, 5.11; $\theta=0$), where the gene for cardiac β -myosin heavy chain is encoded. Analyses of this and other genes for sarcomere proteins identified disease-causing dominant mutations in four kindreds. Cardiac β -myosin heavy-chain missense mutations (Ser532Pro and Phe764Leu) and a deletion in cardiac troponin T (Δ Lys210) caused early-onset ventricular dilatation (average age at diagnosis, 24 years) and diminished contractile function and frequently resulted in heart failure. Affected persons had neither antecedent cardiac hypertrophy (average maximal left-ventricular-wall thickness, 8.5 mm) nor histopathological findings characteristic of hypertrophy.

Conclusions Mutations in sarcomere protein genes account for approximately 10 percent of cases of familial dilated cardiomyopathy and are particularly prevalent in families with early-onset ventricular dilatation and dysfunction. Because distinct mutations in sarcomere proteins cause either dilated or hypertrophic cardiomyopathy, the effects of mutant sarcomere proteins on muscle mechanics must trigger two different series of events that remodel the heart. (N Engl J Med 2000;343:1688-96.)

©2000, Massachusetts Medical Society.

DILATED cardiomyopathy is a relatively common but poorly understood group of disorders that result in heart failure and premature death.¹ Epidemiologic data indicate that 36.5 in 100,000 people have dilated cardiomyopathy. Although ischemic, toxic, metabolic, or infectious causes are recognized, inherited gene defects account for 25 to 30 percent of cases.^{2,3} Of the five mutated genes known to cause dilated cardiomyopathy, four are often associated with additional clinical manifestations. Among these, defects in the cytoskeletal proteins dystrophin,⁴ desmin,^{5,6} and tafazzin^{7,8} produce both myocardial and skeletal-muscle dysfunction, whereas lamin A/C mutations^{7,8} cause ventricular dysfunction with conduction-system disease. Familial dilated cardiomyopathy that is unaccompanied by other clinical manifestations is a heterogeneous disorder,¹⁰ and although disease loci have been defined on chromosomes 1q32,¹¹ 2q11–22,¹² 2q31,¹³ 9q13–22,¹⁴ and 10q21–23,¹⁵ only two disease-causing mutations have been identified, both in the cardiac actin gene.¹⁶

Elucidation of the genetic basis of heritable dilated cardiomyopathy might provide insights into the pathogenetic mechanisms of this disease. To date, studies in this area have implicated defects in the transmission of contractile force as one mechanism for ventricular dilatation and dysfunction. To clarify the pathogenesis of dilated cardiomyopathy, we used molecular genetic approaches to identify other inherited gene mutations that cause this disease. We performed clinical evaluations of the members of a large family in which dilated cardiomyopathy was inherited as an autosomal dominant trait. Genome-wide linkage analyses defined a new disease-associated locus on chro-

From the Cardiovascular Division, Brigham and Women's Hospital, Boston (M.K., S.S., C.E.S.); the Department of Genetics, Harvard Medical School and Howard Hughes Medical Institute, Boston (M.K., S.D.S., S.R.D., P.S., B.M., J.G.S., C.E.S.); the Department of Cardiology, Children's Hospital, Boston (L.S., M.P.M.); the Cardiovascular Division, Massachusetts General Hospital, Boston (M.P.M.); the Department of Pediatrics, Westchester Medical Center, New York Medical College, Valhalla (P.K.W.); and the Department of Medicine, Toronto General Hospital, University of Toronto, Toronto (E.D.W.). Address reprint requests to Dr. Christine Seidman at the Department of Genetics, Harvard Medical School, Alpert Bldg., Rm. 533, 200 Longwood Ave., Boston, MA 02115, or at cseidman@rascal.med.harvard.edu.

Other authors were John Jarcho, M.D., Cardiovascular Division, Brigham and Women's Hospital, Boston; and Lawrence R. Shapiro, M.D., Department of Pediatrics, Westchester Medical Center, New York Medical College, Valhalla.

Drs. Kamisago and S.D. Sharma contributed equally to the article.

mosome 14q11.2–13; this finding implicated the gene for the sarcomere protein cardiac β -myosin heavy chain in this disorder. We then screened the genes encoding this and other sarcomere proteins for mutations that might cause familial dilated cardiomyopathy.

METHODS

Clinical Evaluation

Written informed consent was obtained from all participants in accordance with the requirements of the Brigham and Women's Hospital Human Research Committee. Family members were evaluated by history taking and physical examination, 12-lead electrocardiography, and transthoracic echocardiography by study personnel who had no knowledge of family members' genotype status. Any previous cardiac studies in the subjects were reviewed. Familial dilated cardiomyopathy was diagnosed according to previously described criteria,¹³ in accordance with the suggestions of Mestroni et al.¹⁷ The clinical status of family members who had died was determined on the basis of medical records and postmortem examinations.

Genetic Studies

Linkage Analysis

DNA was extracted from whole blood or from lymphocytes transformed with Epstein–Barr virus and was then amplified with use of the polymerase chain reaction (PCR), as described previously,¹³ to analyze fluorescent-labeled polymorphic microsatellite markers (MapPairs, Set 9, Research Genetics, Huntsville, Ala.) throughout the genome. Amplification products were pooled into prescribed panels, diluted, and resolved on a DNA sequencer (ABI Prism 377XL Sequencer, Applied Biosystems, Foster City, Calif.). Data were analyzed with use of GeneScan and Genotyper software (Applied Biosystems). Two-point lod scores were calculated with use of the program MLINK (version 5.1), and multipoint lod scores with use of Linkmap (both available at <http://linkage.rockefeller.edu/soft/fastlink>). Calculations of lod scores were performed with the assumptions of a disease penetrance of 0.95 and a phenocopy rate of 0.001. The allele frequencies were assessed in a population of unrelated subjects.

Analyses of Candidate Genes

Protein-encoding exons of the cardiac β -myosin heavy chain, troponin T, troponin I, and α -tropomyosin genes were amplified from genomic DNA. (Sequences of all primers used in this study are provided on our Web site at <http://genetics.med.harvard.edu/~seidman>). PCR products were purified with use of kits (QIAquick PCR Purification kits, Qiagen, Santa Clarita, Calif.) and sequenced with a dye-terminator cycle-sequencing system (ABI Prism 377).

Confirmation of Mutations and Genotypes of Family Members

Mutations were independently confirmed, and the genotypes of family members were determined. The mutation Ser532Pro in the gene for β -myosin heavy chain and the deletion Δ Lys210 in the gene for cardiac troponin T were detected by oligonucleotide-specific hybridization; Ser532Pro was also detected by modified restriction-enzyme digestion.¹⁸ The presence of the β -myosin heavy-chain mutation Phe764Leu, which abolishes a *Mbo*I restriction site, was confirmed by genomic DNA digestion with this enzyme.

RESULTS

Clinical investigations of Family A (Table 1) demonstrated autosomal dominant transmission of chamber dilatation and reduced cardiac function (Fig. 1A). Seventeen family members (Fig. 2A) had dilated cardiomyopathy without conduction-system disease, skel-

etal-muscle dysfunction, or other phenotypes. Prior clinical studies of 12 affected persons were noteworthy for the absence of ventricular hypertrophy. In many family members, the onset of disease occurred early in life. Subject V-1 was hospitalized with heart failure at the age of 2 years; heart failure developed and sudden death occurred in Subject III-17 at 20 years of age; Subject III-14 underwent cardiac transplantation for end-stage heart failure at the age of 23 years; and Subject III-16 was referred for evaluation for cardiac transplantation at 32 years of age. Histopathological study of the explanted heart from Subject III-14 (Fig. 1C) showed mildly increased interstitial fibrosis without myocyte or myofibrillar disarray. Progressive ventricular dysfunction caused congestive heart failure in eight other family members. Clinical evaluations in six asymptomatic family members (age range, 11 to 42 years) demonstrated previously unrecognized ventricular dilatation and mild ventricular dysfunction.

Genome-wide linkage analyses in Family A identified a locus associated with dilated cardiomyopathy on chromosome 14, band q11.2–13 (maximal lod score, 5.11 at *D14S990*; $\theta=0$). The family members' status as affected or unaffected and their genotypes were concordant at six loci between *D14S283* and *D14S597*, a 14-cM interval containing the gene for cardiac α - and β -myosin heavy chains. Because the cardiac β isoform is abundantly expressed in ventricular myocardium and because human mutations in cardiac β -myosin heavy chain are known to cause hypertrophic cardiomyopathy, the 38 exons encoding this protein were amplified and sequenced from DNA samples derived from members of Family A.

A single-nucleotide variant (T→C at nucleotide 1680) (Fig. 2B) in exon 16, which would substitute a proline for the normal serine at residue 532 (designated Ser532Pro), was found in samples from affected persons. The sequence variant was independently confirmed by oligonucleotide-specific hybridization, and modified restriction-enzyme digestion¹⁸ was used to determine the genotype of all family members. The T→C transition was present in all affected family members and absent in family members with normal cardiac structure and function (Fig. 2A).

To determine whether other mutations in the cardiac β -myosin heavy chain gene caused dilated cardiomyopathy, DNA samples were sequenced from 20 unrelated, affected persons from families with heritable dilated cardiomyopathy that was unassociated with other phenotypes. Each family was too small for us to conduct informative linkage studies. A C→G transversion was identified at nucleotide 2378 (Fig. 2B) in exon 21, which replaces phenylalanine with leucine at residue 764 (designated Phe764Leu), in Subject I-1 of Family B. This C→G transversion was confirmed by restriction-enzyme digestion, and the genotypes of family members were ascertained (Fig.

TABLE 1. CLINICAL FEATURES OF SUBJECTS WITH MUTATIONS IN CARDIAC β -MYOSIN HEAVY CHAIN AND CARDIAC TROPONIN T.*

FAMILY AND SUBJECT	SEX/AGE	AGE AT DIAGNOSIS	NYHA CLASS	LVED	LVES	FRACTIONAL SHORTENING†	LVWT	CONDITIONS OR OUTCOME
				cm	cm	%		
Family A								
II-2	F/71 yr	51 yr	II	5.8‡	4.2‡	28	10.8	Hypertension
II-3	M/67 yr	57 yr	IV	6.1‡	5.5‡	10	8.9	Hypertension
II-6	F/63 yr	50 yr	II	5.1‡	4.4‡	14	6.1	
II-9	F/59 yr	46 yr	III	7.0‡	6.0‡	14	10.0	
III-1	F/54 yr	NA	II	5.1‡	3.3	35	10.2	
III-2	M/53 yr	NA	II	5.8‡	4.4	24	10.2	
III-4	F/42 yr	39 yr	III	6.1‡	4.8‡	21	7.0	Mitral regurgitation
III-6	F/40 yr	36 yr	III	6.1‡	5.0‡	19	9.4	Normal coronary arteries
III-9	F/23 yr	23 yr	II	5.9‡	4.2‡	29	8.3	
III-11	F/42 yr	42 yr	I	5.2‡	4.1‡	21	8.2	
III-14	M/39 yr	23 yr	IV	7.8‡	6.8‡	13	10.6	Received transplant at 23 yr of age
III-16	M/32 yr	18 yr	IV	9.0‡	7.6‡	16	8.4	
III-17	F/20 yr§	20 yr	IV	NA	NA	NA	NA	Postpartum CHF, sudden death
IV-3	F/14 yr	14 yr	I	5.3	3.6	32	9.4	
IV-5	M/13 yr	13 yr	I	5.4‡	4.0	26	9.9	
IV-6	F/11 yr	11 yr	I	5.5‡	4.1‡	25	8.5	
IV-8	F/21 yr	21 yr	I	5.0‡	3.6	28	8.3	
IV-10	M/19 yr	8 yr	I	5.6‡	4.5‡	20	9.5	
V-1	F/4 yr	2 yr	II-III	4.2‡	3.4‡	19	6.6	CHF at 2 yr of age
Family B								
I-1	M/33 yr	11 yr	III	6.7‡	6.2‡	7	8.0	
II-1	F/8 yr	2 yr	II	4.5‡	3.0	25	7.0	Mitral regurgitation
II-2	F/2 mo§	—	I	NA	NA	NA	NA	Sudden death¶
II-3	F/4 yr	Birth	I	4.4‡	3.1‡	17	6.0	Fetal left ventricular dilatation
Family C								
II-3	M/26 yr§	—	I	NA	NA	NA	NA	Sudden death
II-4	M/27 yr§	—	I	NA	NA	NA	NA	Sudden death
III-3	F/59 yr	53 yr	III	6.3‡	5.5‡	13	10	Normal coronary arteries
III-4	M/26 yr§	—	I	NA	NA	NA	NA	Endocarditis
III-6	M/51 yr	48 yr	III	7.4‡	7.0‡	5	9	
III-7	M/1 mo§	—	I	NA	NA	NA	NA	Sudden death (clinical diagnosis of infantile cardiomyopathy)
III-8	M/8 mo§	—	I	NA	NA	NA	NA	Sudden death (clinical diagnosis of infantile cardiomyopathy)
IV-1	F/29 yr	23 yr	II	6.8‡	5.9‡	13	7	Normal coronary arteries
Family D								
I-1	F/68 yr§	49 yr	IV	NA	NA	NA	NA	Cerebrovascular accident
II-1	F/17 yr§	—	IV	NA	NA	NA	NA	CHF¶
II-2	F/19 yr§	—	IV	NA	NA	NA	NA	Postpartum CHF, sudden death¶
II-4	F/44 yr	23 yr	II	5.3‡	4.3‡	19	8	
III-1	M/15 yr§	14 yr	IV	5.4‡	4.1‡	24	6	CHF¶

*Age is the subject's current age or age at death. NYHA denotes New York Heart Association, NA not available, LVED left ventricular end-diastolic dimension, LVES left ventricular end-systolic dimension, LVWT maximal left-ventricular-wall thickness, and CHF congestive heart failure. The dashes indicate that the age at death was the same as the age at diagnosis.

†The earliest value available for fractional shortening is shown. Values below 28 percent are clearly abnormal.

‡The dimension is greater than the upper 90 percent tolerance limit for body-surface area.

§The age at death is shown.

¶Postmortem examination showed marked dilatation of the right and left ventricles with histologic findings of increased interstitial fibrosis without myocyte disarray.

||Postmortem examination showed cardiomegaly (weight of the heart, 400 g), with marked right ventricular dilatation; the cardiac ultrastructure was normal.

2A). The histories and clinical evaluations of the members of Family B were remarkable for the early onset of ventricular dilatation and dysfunction (Table 1) and for the sudden death of an apparently healthy infant (Subject II-2). Postmortem cardiac examination revealed ventricular dilatation and extensive macroscop-

ic and microscopic fibrosis. Typical histopathological features of hypertrophic cardiomyopathy, such as myocyte hypertrophy and disarray, were notably absent. Serial cardiac evaluations of the child's father and two surviving siblings showed ventricular dilatation and dysfunction.

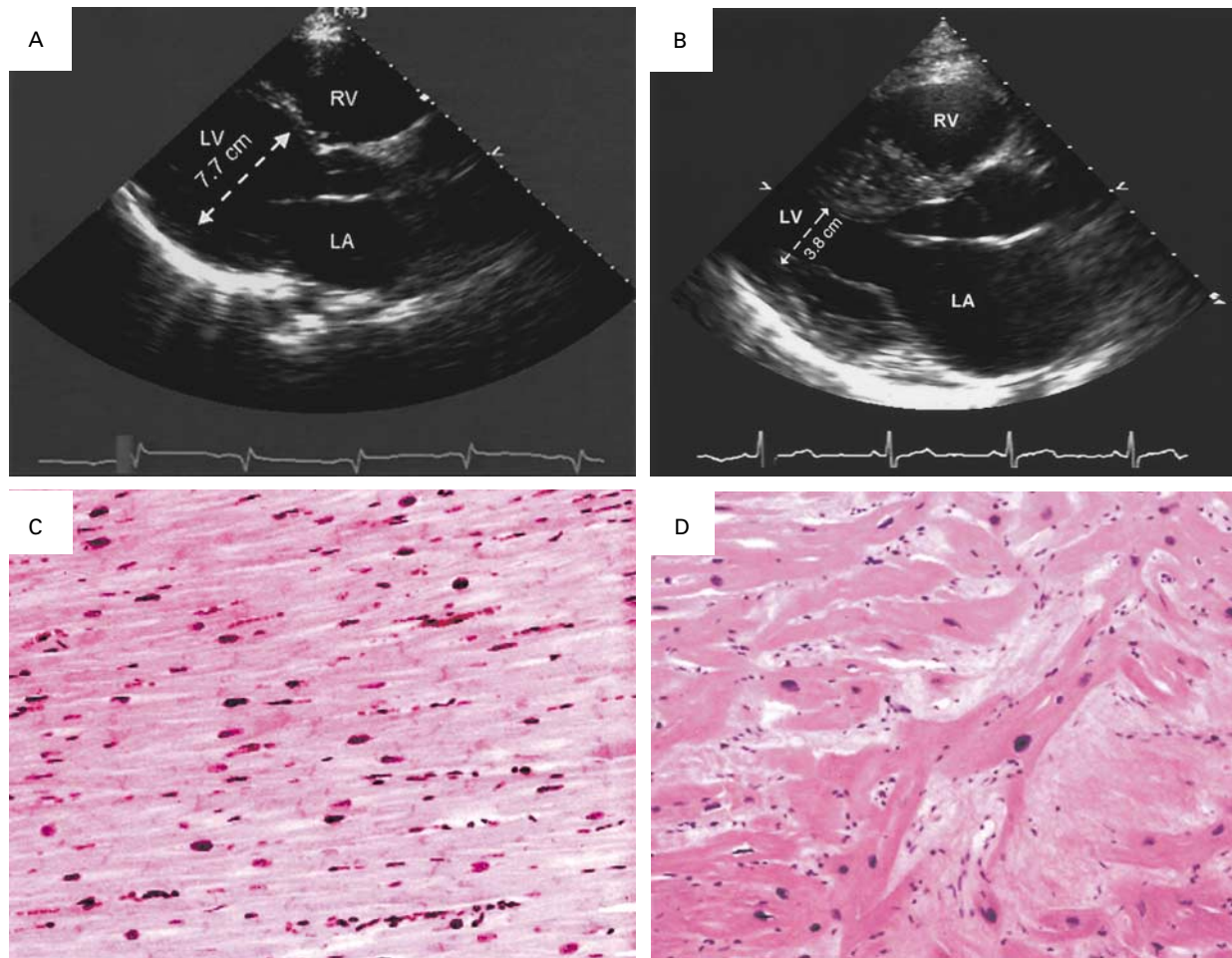

Figure 1. Clinical Manifestations of Dilated and Hypertrophic Cardiomyopathy Due to Missense Mutations in the Gene for Cardiac β -Myosin Heavy Chain.

Panel A shows a two-dimensional echocardiogram of Subject III-16 in Family A at the age of 30 years. Marked ventricular dilatation (left ventricular end-diastolic dimension, 7.7 cm) is evident, and there is no septal or free-wall hypertrophy. LV denotes left ventricle, RV right ventricle, and LA left atrium. The missense mutation Arg719Gln in the gene for cardiac β -myosin heavy chain causes marked interventricular septal hypertrophy (left ventricular end-diastolic dimension, 3.8 cm) without ventricular dilatation (Panel B). A left ventricular specimen from the explanted heart of Subject III-14 in Family A (Panel C, $\times 200$) is characterized by nonspecific abnormalities (i.e., mildly increased interstitial fibrosis) but not by myocyte and myofibrillar disarray (hematoxylin and eosin). The missense mutation Arg719Gln in the gene for cardiac β -myosin heavy chain causes myocyte hypertrophy, disarray, and abundant interstitial fibrosis (hematoxylin and eosin) (Panel D, $\times 200$).

We hypothesized that allelic mutations in the genes for other sarcomere proteins could also cause dilated cardiomyopathy. To test this hypothesis, genes encoding cardiac troponin T, troponin I, and α -tropomyosin were amplified and sequenced from DNA samples derived from the remaining 19 unrelated persons with dilated cardiomyopathy. A deletion of three nucleotides (AGA) of the cardiac troponin T gene was identified in samples from two unrelated families (Families C and D) (Fig. 2); this deletion is predicted to eliminate one of four lysine residues encoded in tandem in exon 13 (designated Δ Lys 210, according to

the numbering of Townsend et al.¹⁹). Haplotype analyses indicated that each mutation arose independently in these families (data not shown). The deletion was confirmed by oligonucleotide-specific hybridization, and genotypes for all members of Families C and D were determined (Fig. 2A). The mutation Δ Lys 210 in the cardiac troponin T gene was identified in members of each family who are being followed clinically because they have unexplained ventricular dilatation and marked ventricular dysfunction. None of their serial echocardiograms revealed hypertrophic heart disease. In the medical records of deceased members

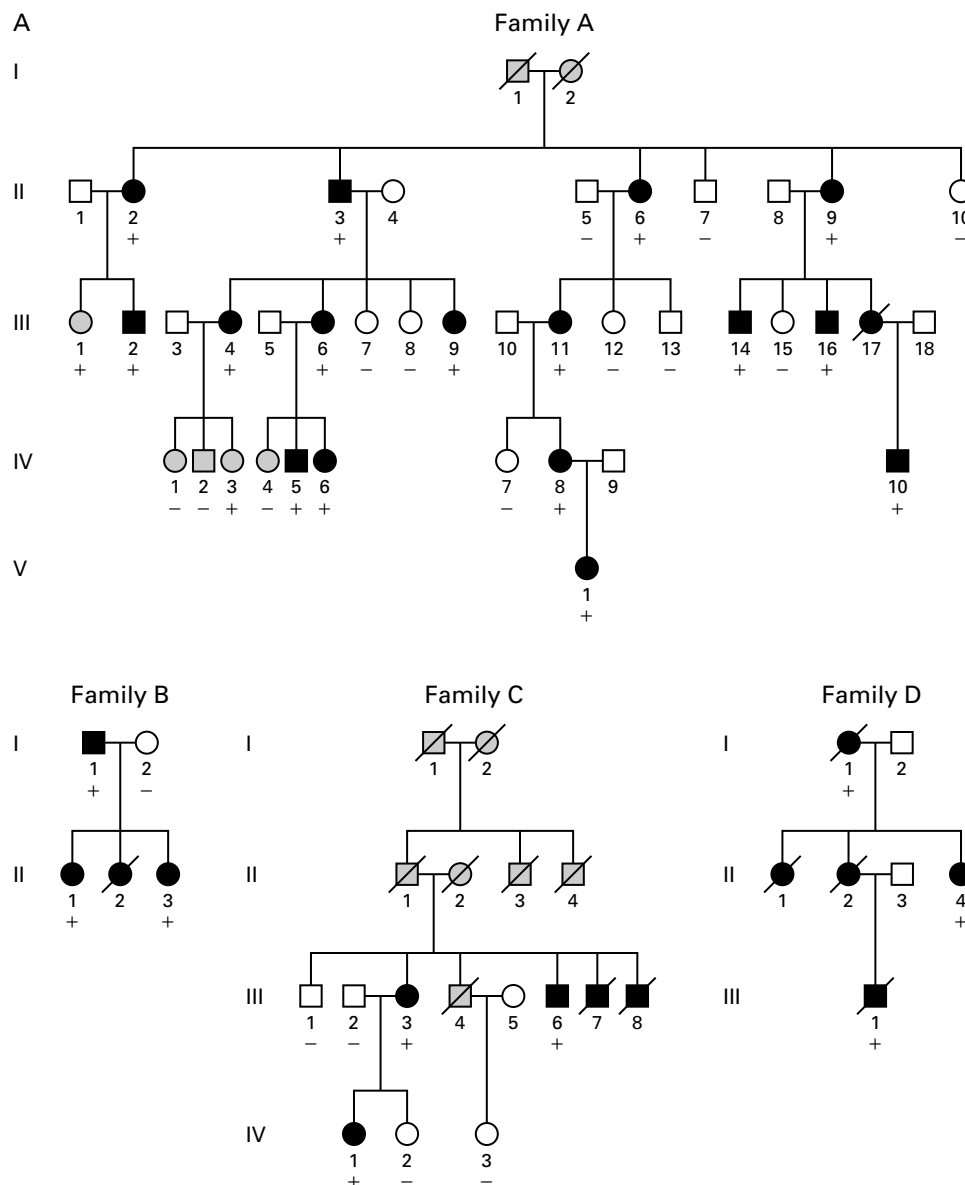

Figure 2. Familial Dilated Cardiomyopathy Associated with Mutations in the Genes for Cardiac β -Myosin Heavy Chain and Cardiac Troponin T.

Panel A shows the pedigrees of four families affected by dilated cardiomyopathy. Squares indicate male family members, circles female family members, symbols with a slash members who had died, solid symbols affected members, open symbols unaffected members, and shaded symbols members of unknown clinical status. Plus signs indicate the presence of a mutation, and minus signs the absence of a mutation. In the four families, clinical status was assessed without knowledge of genotype status. Panel B (facing page) shows sequence analyses of DNA from affected members of Families A, B, C, and D after polymerase-chain-reaction amplification. The mutation Ser532Pro in the gene for cardiac β -myosin heavy chain is caused by a T→C transition at nucleotide 1680. Phe764Leu in the same gene results from a C→G transition at nucleotide 2378. The mutation Δ Lys210 in the gene for cardiac troponin T results from the deletion of three base pairs (AAG) in exon 13.

of Family C, the sudden deaths of two infants with infantile cardiomyopathy and three young adults were notable. Three deaths attributed to congestive heart failure in Family D occurred in persons less than 20 years of age (Table 1).

The Ser532Pro and Phe764Leu substitutions in

cardiac β -myosin heavy chain and the Δ Lys210 deletion in cardiac troponin T were not found in analyses of chromosomes from more than 200 unrelated normal subjects (data not shown). Mutations at these residues have not been associated with hypertrophic cardiomyopathy.²⁰ Each defect perturbs a conserved

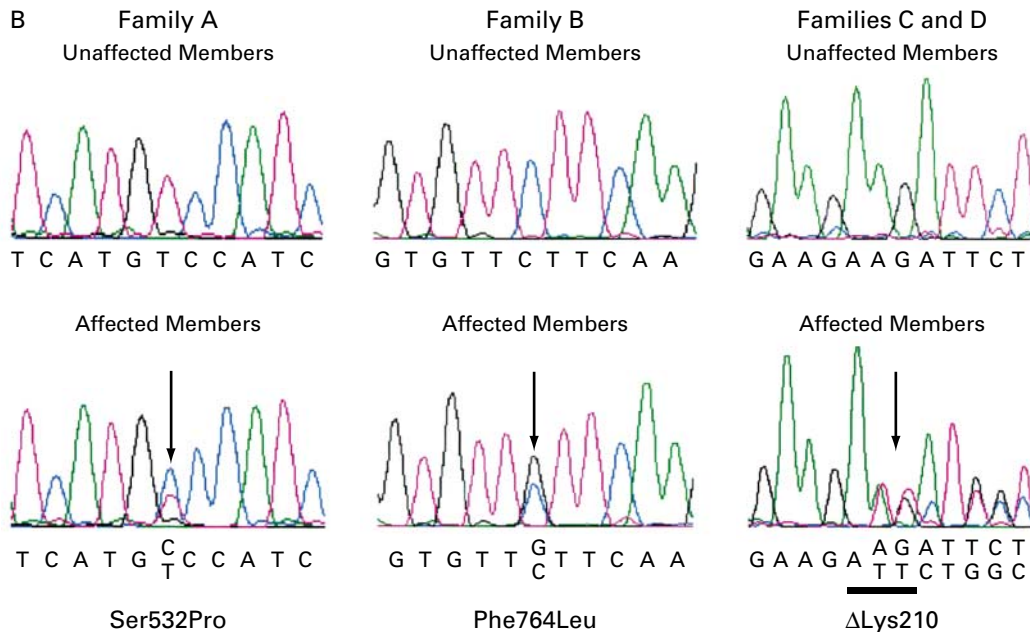

residue (Table 2), suggesting that these substitutions have functional consequences. We conclude that the missense mutations Ser532Pro and Phe764Leu in the gene for cardiac β -myosin heavy chain and Δ Lys 210 in the cardiac troponin T gene cause dilated, not hypertrophic, cardiomyopathy.

DISCUSSION

The histopathological and pathophysiologic features of hypertrophic cardiomyopathy are quite different from those of dilated cardiomyopathy. Increased ventricular volumes with ventricular wall thinning (Fig. 1A), nonspecific histologic features (Fig. 1C), and moderate-to-severe diminution of contractile function characterize dilated cardiomyopathy.¹⁻³ In contrast, hypertrophic cardiomyopathy alters the morphologic features of the heart by markedly thickening ventricular walls with disproportionate (asymmetric) involvement of the interventricular septum (Fig. 1B), produces distinctive cellular histopathological features, notably myocyte disarray with interstitial fibrosis (Fig. 1D), and causes hyperdynamic contractile function with reduced ventricular volumes.^{21,22}

A small fraction (<10 percent) of patients with hypertrophic cardiomyopathy have end-stage disease late in life that is characterized by wall thinning and diminished systolic function.^{22,23} Although end-diastolic volumes are larger than in the hypertrophic phase of disease, the degree of dilation rarely approaches the ventricular dimensions that characterize primary dilated cardiomyopathy.²⁴ The very early age at which heart failure develops in the families described here, without prior electrocardiographic or echocardiographic

evidence of cardiac hypertrophy, and the absence of myocyte disarray indicate that these families have primary dilated cardiomyopathy and not end-stage (“burnt-out”) hypertrophic heart disease.

How do allelic mutations in cardiac troponin T or the cardiac β -myosin heavy chain produce these distinct cardiac phenotypes? Integration of recent biophysical information about contractile proteins provides some insights into this question. Muscle contraction requires the transmission of a power stroke of coordinated movement through thick and thin sarcomere filaments (Fig. 3). During this process, domains of myosin undergo sequential conformational changes to disrupt actin interactions, foster hydrolysis of ATP, and then rebind actin.²⁶ Troponin T, one component of a ternary complex of proteins (troponins T, C, and I), transmits calcium signals that regulate actin–myosin interactions and ATPase activity.²⁷

Analyses of muscle mechanics in cardiac myocytes from mice that were engineered to contain a human hypertrophic myosin missense mutation²⁸ demonstrated enhanced contractile function. As compared with normal myocytes, those with mutant sarcomeres exhibited increased actin-activated ATPase activity, greater force production, and faster actin-filament sliding²⁵; these properties may contribute to the hyperdynamic cardiac contractile function observed in patients with hypertrophic cardiomyopathy.

The sarcomere mutations that we have shown to cause dilated cardiomyopathy are likely to diminish the mechanical function of cardiac myocytes. Cardiac troponin T residue 210 is located in a domain (cardiac residues 207 through 234) that is responsible

TABLE 2. CONSERVATION OF SEQUENCES FLANKING MUTATIONS ASSOCIATED WITH DILATED CARDIOMYOPATHY IN HUMANS.

SPECIES AND SARCOMERE PROTEIN	AMINO ACIDS FLANKING RESIDUE 532	AMINO ACIDS FLANKING RESIDUE 764	PERCENTAGE IDENTITY*
Mutant myosin			
Ser532Pro P		
Phe764Leu	 L	
Myosin			
Human cardiac β	PMGIMS I L E E E C M F	G H T K V F F K A G L L G L L E	
Human cardiac α			93
Rat cardiac α			92
Human perinatal skeletal	. L . . F		81
Human IIa F		81
Chicken fast skeletal F		81
Scallop striated L T V N . .	60
<i>Drosophila melanogaster</i> L S N R V . . Q M .	55
AMINO ACIDS FLANKING RESIDUE 210			
Mutant troponin T			
Δ Lys 210 Δ		
Troponin T			
Human cardiac†	REKKKKI L A E R R K V L A I D H L N E D Q L R - E K A K		
Bovine cardiac			89
Mouse cardiac	 A	85
Rat cardiac			87
Rabbit cardiac			89
Human fast skeletal	. . M P . N G . . K . . D . .		60
Rabbit fast skeletal	. . M P . N S D E K . . D . .		56
Chicken skeletal	. . T . . V P . N K . . D . .		58
Quail fast skeletal	. . T . . V P . N K . . D . .		58
Human slow skeletal	. . M . V R . . S . . K . P . D . . Y M G . E Q		55
Mouse slow skeletal	. . M . L R . . S . . K . P . N . . Y M G Q		60
Chicken slow skeletal	. . M . L R K . P . H . E . M R . . E . . A . .		61

*“Percentage Identity” is the percentage of the sequence that is identical to human sequence as based on protein sequences from the following GenBank accession numbers: human cardiac β -myosin heavy chain, NP000248; human cardiac α -myosin heavy chain, P13533; rat cardiac α -myosin heavy chain, P02563; human perinatal skeletal myosin heavy chain, P13535; human IIa myosin heavy chain, AAD29950; chicken fast skeletal myosin heavy chain, P13538; scallop striated muscle myosin heavy chain, AAB19994; *D. melanogaster* muscle myosin heavy chain, AAA28687; human cardiac troponin T, S64668; bovine cardiac troponin T, A28008; mouse cardiac troponin T, NP035749; rat cardiac, NP036808; rabbit cardiac, A25345; human fast skeletal, AAF21629; rabbit fast skeletal troponin T, TPRBTS; chicken skeletal troponin T, M22156; quail fast skeletal troponin T, B34327; human slow skeletal troponin T, CAA09752; mouse slow skeletal troponin T, AAD00737; chicken slow skeletal troponin T, BAA12727.

†Sequences of a 16-bp insertion found in slow skeletal isoforms of troponin T are indicated by a dash in the human cardiac troponin T sequences.

for calcium-sensitive troponin C binding²⁹ and that contains six conserved lysines. Three of these basic residues (lysines 208, 209, and 210) (Table 2) participate in forming a tight binary complex with troponin C,³⁰ possibly by means of complementary interactions with a ring of acidic residues located on the surface of troponin C.³¹ Loss of troponin T lysine residue 210 should reduce these ionic interactions and diminish activation of calcium-stimulated actomyosin ATPase, just as occurs with mutagenesis of troponin C acidic residues.³² As a consequence, the power stroke of contraction would be reduced (Fig.

3). Notably, none of the mutations in cardiac troponin T that cause hypertrophic cardiomyopathy alter lysine residues in this calcium-sensitive, troponin C-binding domain²⁰; such defects apparently perturb different biophysical events that trigger cardiac hypertrophy.

The location of cardiac myosin mutations that cause dilated cardiomyopathy also suggests that such mutations impair contractile function. Ser532Pro maps within an α -helical structure of the lower 50-kd domain in myosin that is strictly conserved throughout evolution (Table 2) and contributes to the tight bind-

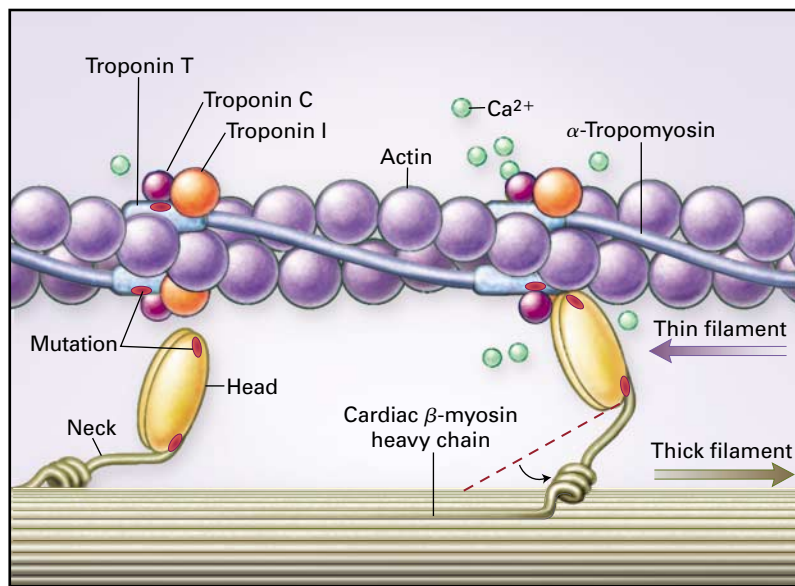

Figure 3. Generation of a Power Stroke by Myosin and Actin in Sarcomere Filaments.

Cardiac contraction occurs when calcium binds the troponin complex (subunits I, C, and T) and α -tropomyosin and releases the inhibition of myosin–actin interactions by troponin I. ATPase activity and binding of actin by the globular myosin head result in conformational changes that bend the neck (curved arrow), which is also termed the lever arm, and result in the sliding of thick filaments in relation to thin filaments (solid arrows). Some mutations of sarcomere proteins enhance contractile function²⁵ and cause hypertrophic cardiomyopathy. In contrast, the mutations Ser532Pro or Phe764Leu in cardiac β -myosin heavy chain and Δ Lys210 in cardiac troponin (shown as red spots) may reduce the production of contractile force by the sarcomere; these defects and actin mutations¹⁶ cause dilated cardiomyopathy.

ing of actin.³³ By the substitution of proline for serine at residue 532, this α -helix is broken, which disrupts stereospecific interactions between myosin and actin; tight stereospecific interactions are critical for initiating the power stroke of contraction.³³ Cardiac β -myosin heavy chain residue 764 resides in the converter region, one of several flexible “joints” in myosin that undergo conformational changes during the contractile cycle.³⁴ The converter region, along with the myosin relay domain and the SH1 helix, functions as a hinge that transmits movement and directionality from the head of myosin to the neck, thereby propelling the thick filament (Fig. 3). Phenylalanine 764 sits at the center of this hinge and is invariant in all known muscle myosins (Table 2). Substitution of leucine at this position might alter the magnitude³⁵ or polarity³⁶ of transmitted movement and thereby diminish the efficiency of contraction.

Previous studies have suggested that cytoskeletal defects outside the sarcomere may be one mechanism for the pathogenesis of dilated cardiomyopathy.^{37,38} The mutations in cardiac β -myosin heavy chain and troponin T that are described here suggest a different mechanism — namely, deficits of force generation

by the sarcomere in cardiac muscle. Furthermore, our data suggest that the distinct biophysical events perturbed by allelic mutations in contractile genes trigger divergent signaling pathways that remodel the heart in ways that result in a dilated or hypertrophic phenotype. Elucidation of the components of these pathways may suggest therapeutic interventions that are also relevant to hypertrophic and dilated heart disease with nongenetic causes.

Demonstration that mutations in cardiac β -myosin heavy chain and cardiac troponin T, along with two previously reported mutations in cardiac actin,¹⁶ cause dilated cardiomyopathy implicates mutations in other sarcomere genes in causing this disorder. Because cardiac β -myosin heavy chain and cardiac troponin T mutations were identified in 3 of 20 persons with dilated cardiomyopathy who were studied without prior linkage data to indicate a mutation within a particular gene, we estimate that at least 10 percent of cases of familial dilated cardiomyopathy may be attributed to mutations in the genes for sarcomere proteins. Although dilated cardiomyopathy is unusual before middle age, the medical histories of families with cardiac β -myosin heavy chain, cardiac troponin

T, and actin¹⁶ gene mutations document congestive heart failure and sudden death in children and young adults. We conclude that mutations in genes for sarcomere proteins are particularly prevalent as causes of cardiac dilatation and dysfunction in young people.

Supported by grants from the British Heart Foundation, the Howard Hughes Medical Institute, and the National Heart, Lung, and Blood Institute.

We are indebted to the families and physicians who made these studies possible.

REFERENCES

- Cohn JN, Bristow MR, Chien KR, et al. Report of the National Heart, Lung, and Blood Institute Special Emphasis Panel on heart failure research. *Circulation* 1997;95:766-70.
- Michels VV, Moll PP, Miller FA, et al. The frequency of familial dilated cardiomyopathy in a series of patients with idiopathic dilated cardiomyopathy. *N Engl J Med* 1992;326:77-82.
- Grunig E, Tasman JA, Kucherer H, Franz W, Kubler W, Katus HA. Frequency and phenotypes of familial dilated cardiomyopathy. *J Am Coll Cardiol* 1998;31:186-94.
- Towbin JA, Hejtmancik JF, Brink P, et al. X-linked dilated cardiomyopathy: molecular genetic evidence of linkage to the Duchenne muscular dystrophy (dystrophin) gene at the Xp21 locus. *Circulation* 1993;87:1854-65.
- Li D, Tapscoft T, Gonzalez O, et al. Desmin mutation responsible for idiopathic dilated cardiomyopathy. *Circulation* 1999;100:461-4.
- Dalakas MC, Park K-Y, Semino-Mora C, Lee HS, Sivakumar K, Goldfarb LG. Desmin myopathy, a skeletal myopathy with cardiomyopathy caused by mutations in the desmin gene. *N Engl J Med* 2000;343:770-80.
- Bione S, D'Amado P, Maestrini E, Gedeon AK, Bolhuis PA, Toniolo D. A novel X-linked gene, *G4.5*, is responsible for Barth syndrome. *Nat Genet* 1996;12:385-9.
- D'Adamo P, Fassone L, Gedeon A, et al. The X-linked gene *G4.5* is responsible for different infantile dilated cardiomyopathy. *Am J Hum Genet* 1997;61:862-7.
- Fatkin D, MacRae C, Sasaki T, et al. Missense mutations in the rod domain of the lamin A/C gene as causes of dilated cardiomyopathy and conduction-system disease. *N Engl J Med* 1999;341:1715-24.
- Mestroni L, Rocco C, Gregori D, et al. Familial dilated cardiomyopathy: evidence for genetic and phenotypic heterogeneity. *J Am Coll Cardiol* 1999;34:181-90.
- Durand J-B, Bachinski L, Bieling LC, et al. Localization of a gene responsible for familial dilated cardiomyopathy to chromosome 1q32. *Circulation* 1995;92:3387-9.
- Jung M, Pöpping I, Perrot A, Ellmer AE, Reia A, Osterziel KJ. A family with autosomal dominant dilated cardiomyopathy maps to a novel locus in chromosome 2. *Circulation* 1998;98:Suppl I:I-246. abstract.
- Siu BL, Niimura H, Osborne JA, et al. Familial dilated cardiomyopathy locus maps to chromosome 2q31. *Circulation* 1999;99:1022-6.
- Krajinovic M, Pinamonti B, Sinagra G, et al. Linkage of familial dilated cardiomyopathy to chromosome 9. *Am J Hum Genet* 1995;57:846-52.
- Bowles KR, Gajarski R, Porter P, et al. Gene mapping of familial autosomal dominant dilated cardiomyopathy to chromosome 10q21-23. *J Clin Invest* 1996;98:1355-60.
- Olson TM, Michels VV, Thibodeau SN, Tai Y-S, Keating MT. Actin mutations in dilated cardiomyopathy, a heritable form of heart failure. *Science* 1998;280:750-2.
- Mestroni L, Maisch B, McKenna WJ, et al. Guidelines for the study of familial dilated cardiomyopathies. *Eur Heart J* 1999;20:93-102.
- Russ AP, Maerz W, Ruzicka V, Stein U, Gross W. Rapid detection of the hypertension-associated Met²³⁵→Thr allele of the human angiotensinogen gene. *Hum Mol Genet* 1993;2:609-10.
- Townsend PJ, Farza H, MacGeoch C, et al. Human cardiac troponin T: identification of fetal isoforms and assignment of the TNNT2 locus to chromosome 1q. *Genomics* 1994;21:311-6.
- FHC mutation database. Sydney, Australia: Royal Prince Alfred Hospital, 2000. (See <http://www.angis.org.au/Databases/Heart/>.) (See NAPS document no. 05575 for 10 pages, c/o Microfiche Publications, 248 Hempstead Tpke., West Hempstead, NY 11552.)
- Seidman CE, Seidman JG. Molecular genetics of inherited cardiomyopathies. In: Chien KR, ed. *Molecular basis of cardiovascular disease: a companion to Braunwald's Heart Disease*. Philadelphia: W.B. Saunders, 1999:251-63.
- Wigle ED, Rakowski H, Kimball BP, Williams WG. Hypertrophic cardiomyopathy: clinical spectrum and treatment. *Circulation* 1995;92:1680-92.
- Hina K, Kusachi S, Iwasaki K, et al. Progression of left ventricular enlargement in patients with hypertrophic cardiomyopathy: incidence and prognostic value. *Clin Cardiol* 1993;16:403-7.
- Spirito P, Maron BJ, Bonow RO, Epstein SE. Occurrence and significance of progressive left ventricular wall thinning and relative cavity dilatation in hypertrophic cardiomyopathy. *Am J Cardiol* 1987;60:123-9.
- Tyska MJ, Hayes E, Giewat M, Seidman CE, Seidman JG, Warshaw DM. Single-molecule mechanics of R403Q cardiac myosin isolated from the mouse model of familial hypertrophic cardiomyopathy. *Circ Res* 2000;86:737-44.
- Rayment I, Smith C, Yount RG. The active site of myosin. *Annu Rev Physiol* 1996;58:671-702.
- Tobacman LS. Thin filament-mediated regulation of cardiac contraction. *Annu Rev Physiol* 1996;58:447-81.
- Geisterfer-Lowrance AAT, Christie M, Conner DA, et al. A mouse model of familial hypertrophic cardiomyopathy. *Science* 1996;272:731-4.
- Jha PK, Leavis PC, Sarkar S. Interaction of deletion mutants of troponins I and T: COOH-terminal truncation of troponin T abolishes troponin I binding and reduces Ca²⁺ sensitivity of the reconstituted regulatory system. *Biochemistry* 1996;35:16573-80.
- Leszyk J, Collins JH, Leavis PC, Tao T. Cross-linking of rabbit skeletal muscle troponin subunits: labeling of cysteine-98 of troponin C with 4-maleimidobenzophenone and analysis of products formed in the binary complex with troponin T and the ternary complex with troponins I and T. *Biochemistry* 1988;27:6983-7.
- Houdusse A, Love ML, Dominguez R, Grabarek Z, Cohen C. Structures of four Ca²⁺-bound troponin C at 2.0 Å resolution: further insights into the Ca²⁺-switch in the calmodulin superfamily. *Structure* 1997;5:1695-711.
- Kobayashi T, Zhao X, Wade R, Collins JH. Involvement of conserved, acidic residues in the N-terminal domain of troponin C in calcium-dependent regulation. *Biochemistry* 1999;38:5386-91.
- Rayment I, Rypniewski WR, Schmidt-Base K, et al. Three-dimensional structure of myosin subfragment-1: a molecular motor. *Science* 1993;261:50-8.
- Houdusse A, Kalabokis VN, Himmel D, Szent-Gyorgyi AG, Cohen C. Atomic structure of scallop myosin subfragment S1 complexed with MgADP: a novel conformation of the myosin head. *Cell* 1999;97:459-70.
- Cope MJTV, Whisstock J, Rayment I, Kendrick-Jones J. Conservation within the myosin motor domain: implications for structure and function. *Structure* 1996;4:969-87.
- Wells AL, Lin AW, Chen LQ, et al. Myosin VI is an actin-based motor that moves backwards. *Nature* 1999;401:505-8.
- Chien KR. Stress pathways and heart failure. *Cell* 1999;98:555-8.
- Towbin JA, Bowles KR, Bowles NE. Etiologies of cardiomyopathy and heart failure. *Nat Med* 1999;5:266-7.